

NOTE:
ELECTRICAL:100% OPEN SHORT & MISS WIRE TEST;
ALL MATERIAL BE ROHS & REACH COMPLIANT

⑤	TEAR OFF BOX	SIZE:26*26*21CM	1	PCS
④	LABEL	The product labeling size:60*35MM, Carton label size:90*60MM	1	PCS
③	PRINTING	InLine LAN CABLE CAT.6 S/FTP PIMF 4x2xAWG23/1 Halogen free 001M 002M ... 50M		
②	PACKAGE	Net volume		
①	CABLE	S/FTP CAT 6 :(1*0.56BC*1P+AL-FOIL)*4PAIRS + D(1*0.50BC TIN)+ BRAID(16*5/0.12AL-MG)+TEAR LINE+CABLE JACKET:LSZH , OD=6.0±0.2MM , COLOR:P021C ORANGE	50	M
No.	PART NAME	DESCRIPTION	QTY	REMARK

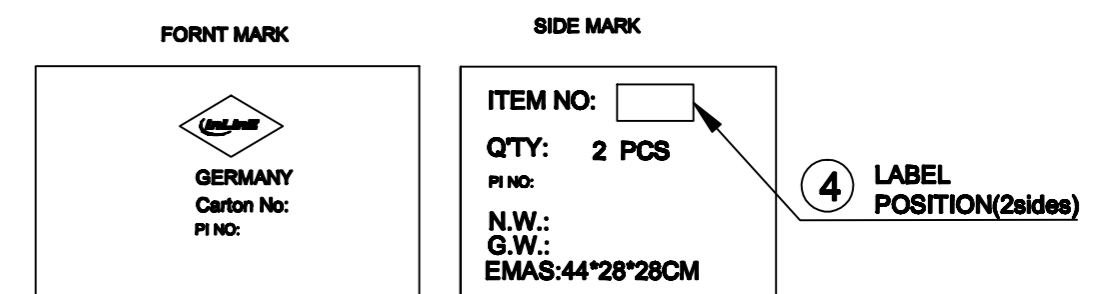

DRAW No.		NAME	S/FTP CAT 6 50M CABLE	
CUSTOMER	Inline		MAPE	TOLERANCE
CUSTOMER No.	70550			X. ±1.00 X.X ±0.50
APPROVE BY	CHECK BY	DRAW BY	SCALE	MM
			PAGE	1/1

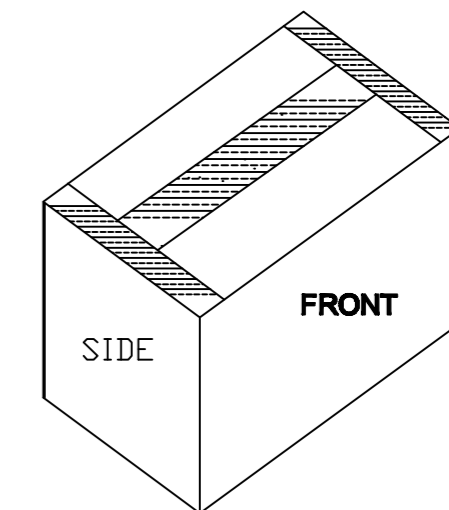
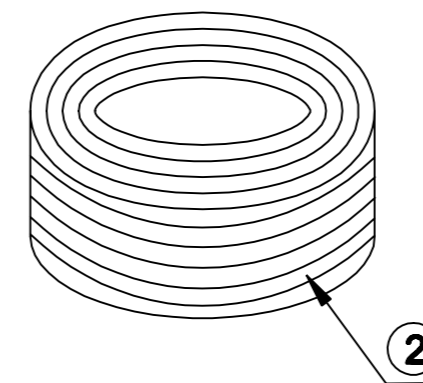
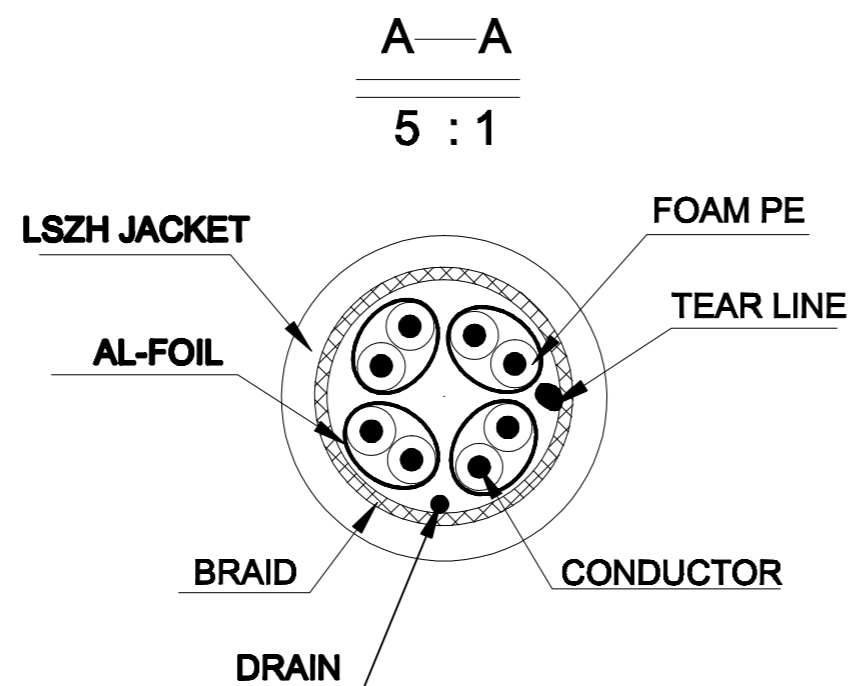
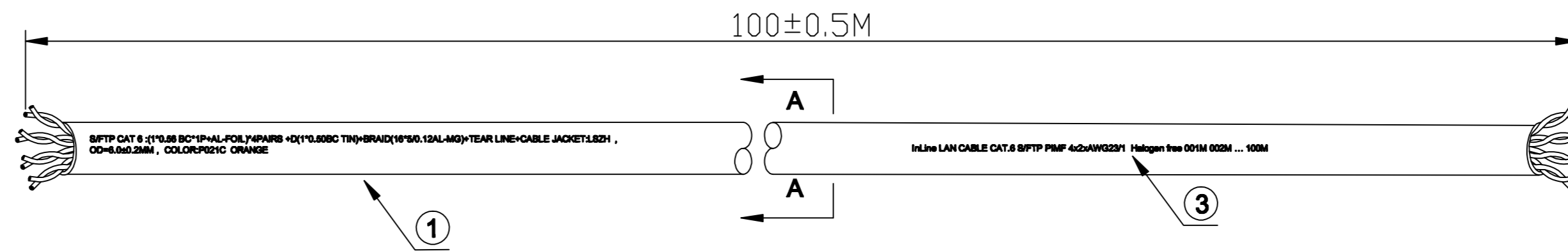

NOTE:
ELECTRICAL:100% OPEN SHORT & MISS WIRE TEST;
ALL MATERIAL BE ROHS & REACH COMPLIANT

⑤	COLOR BOX	SIZE:37*12*37CM	1	PCS
④	LABEL	The product labeling size:60*35MM, Carton label size:90*60MM	1	PCS
③	PRINTING	InLine LAN CABLE CAT.6 S/FTP PIMF 4x2xAWG23/1 Halogen free 001M 002M ... 100M		
②	PACKAGE	PE FILM, PAN SCROLLING		
①	CABLE	S/FTP CAT 6 :(1*0.56BC*1P+AL-FOIL)*4PAIRS+D(1*0.50BC TIN)+BRAID(16*5/0.12AL-MG)+TEAR LINE+CABLE JACKET:LSZH , OD=6.0±0.2MM , COLOR:P021C ORANGE	100	M
No.	PART NAME	DESCRIPTION	QTY	REMARK

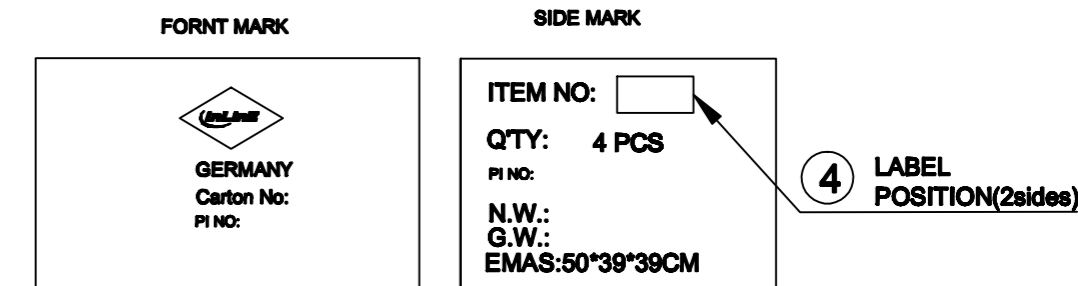

DRAW No.		NAME	S/FTP CAT 6 100M CABLE	
CUSTOMER	Inline		MAPE	TOLERANCE
CUSTOMER No.	70501			X. ±1.00 X.X ±0.50
APPROVE BY	CHECK BY	DRAW BY	SCALE	MM
			PAGE	1/1

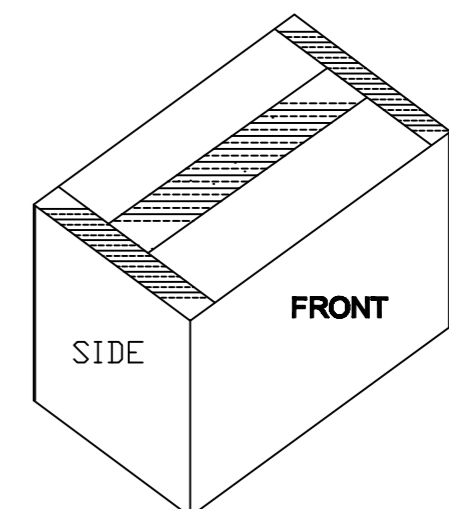
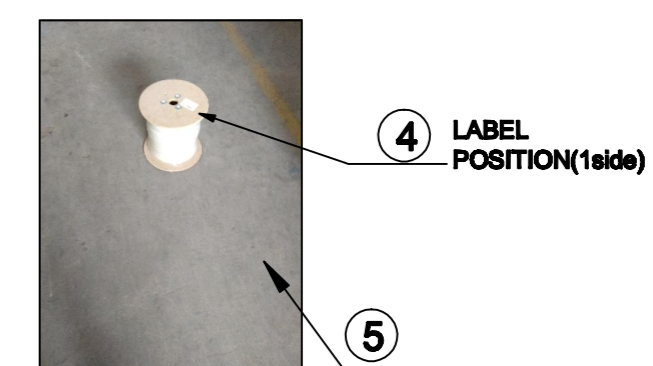
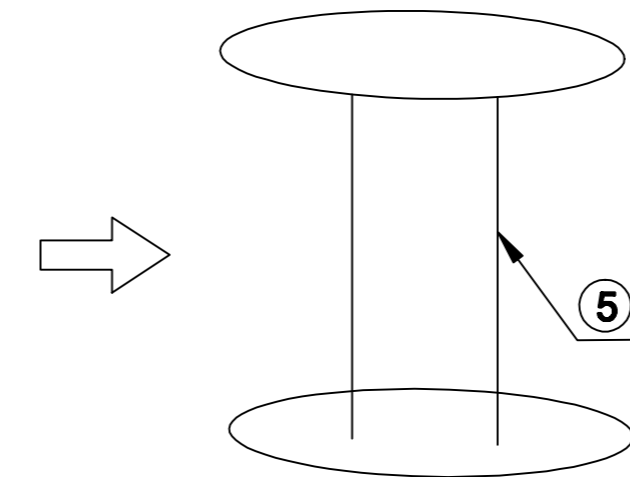
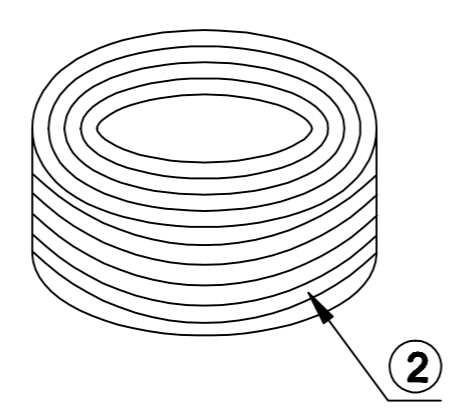
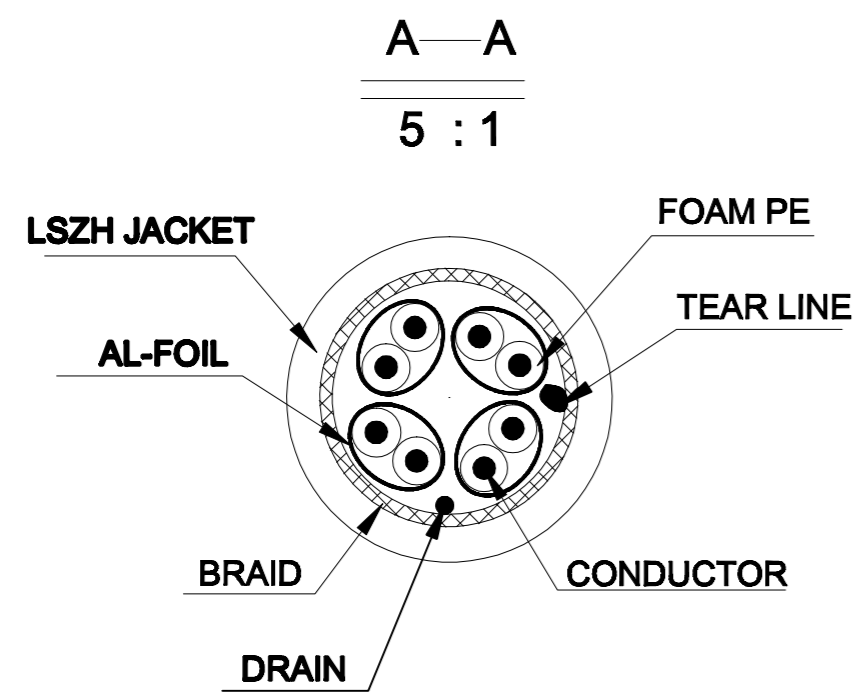
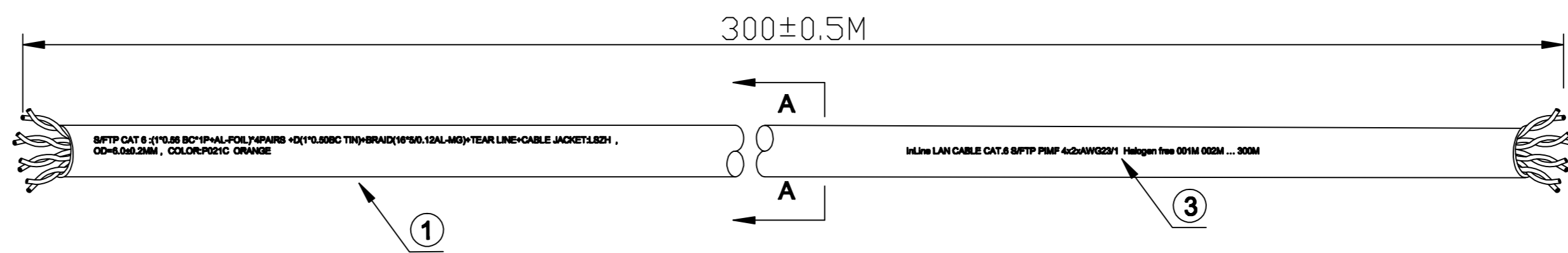

NOTE:
ELECTRICAL:100% OPEN SHORT & MISS WIRE TEST;
ALL MATERIAL BE ROHS & REACH COMPLIANT

⑤	TRENCHER	SIZE: ϕ 32.5*H24CM	1	PCS
④	LABEL	The product labeling size:60*35MM, Carton label size:90*60MM	1	PCS
③	PRINTING	InLine LAN CABLE CAT.6 S/FTP PIMF 4x2xAWG23/1 Halogen free 001M 002M ... 300M		
②	PACKAGE	PE FILM, PAN SCROLLING		
①	CABLE	S/FTP CAT 6 :(1*0.56BC*1P+AL-FOIL)*4PAIRS+D(1*0.50BC TIN)+ BRAID(16*5/0.12AL-MG)+TEAR LINE+CABLE JACKET:LSZH , OD=6.0±0.2MM , COLOR:P021C ORANGE	300	M
No.	PART NAME	DESCRIPTION	QTY	REMARK

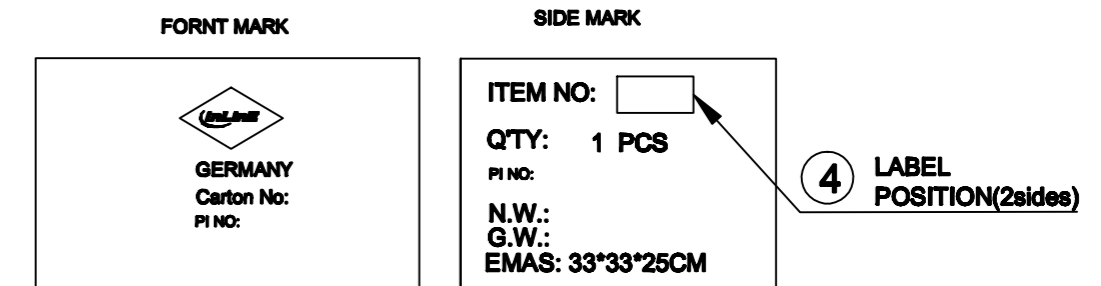

DRAW No.		NAME	S/FTP CAT 6 300M CABLE	
CUSTOMER	Inline		MAPE	TOLERANCE
CUSTOMER No.	70503			X. \pm 1.00 X.X \pm 0.50
APPROVE BY	CHECK BY	DRAW BY	SCALE	MM
			PAGE	1/1

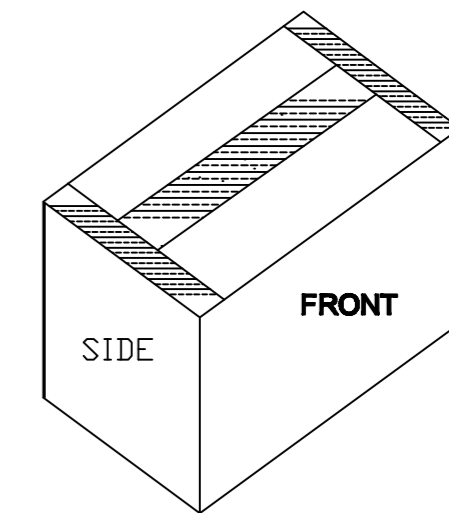
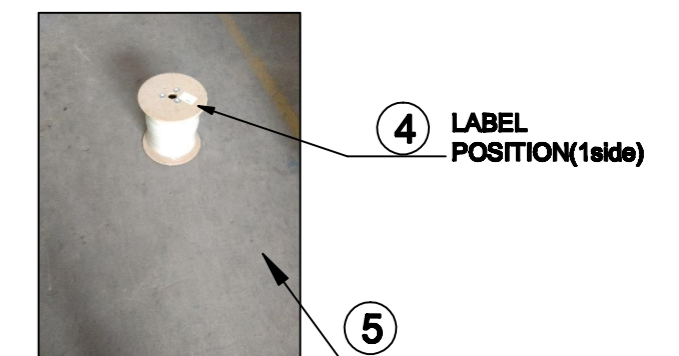
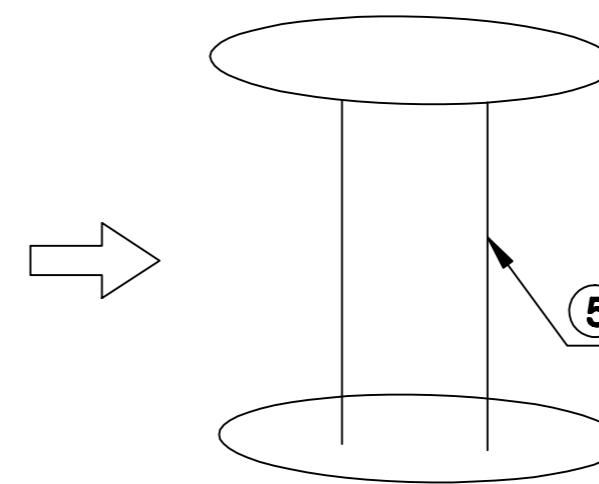
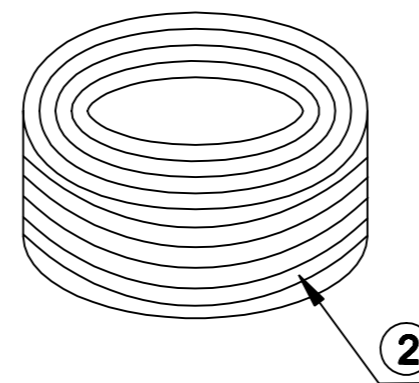
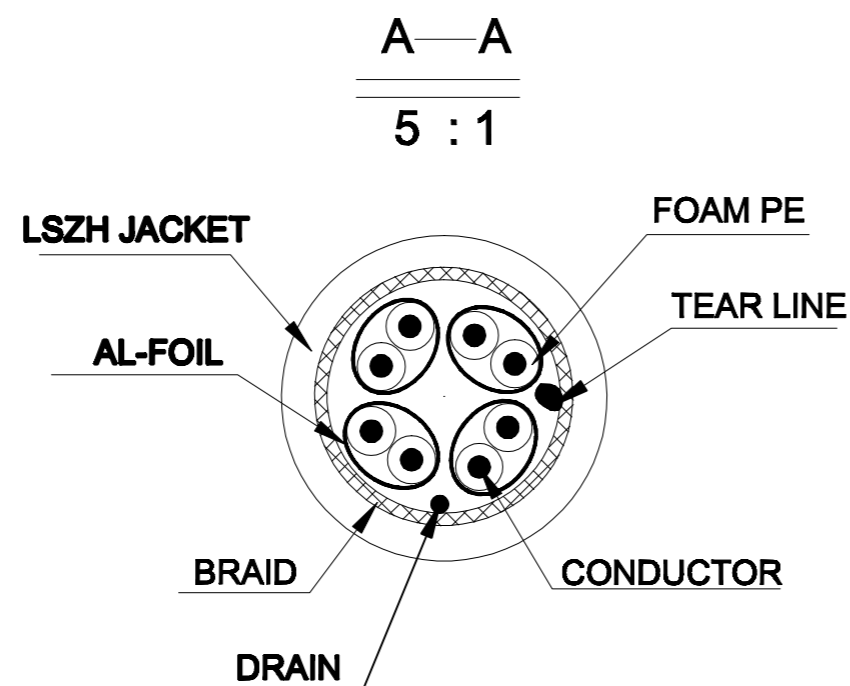
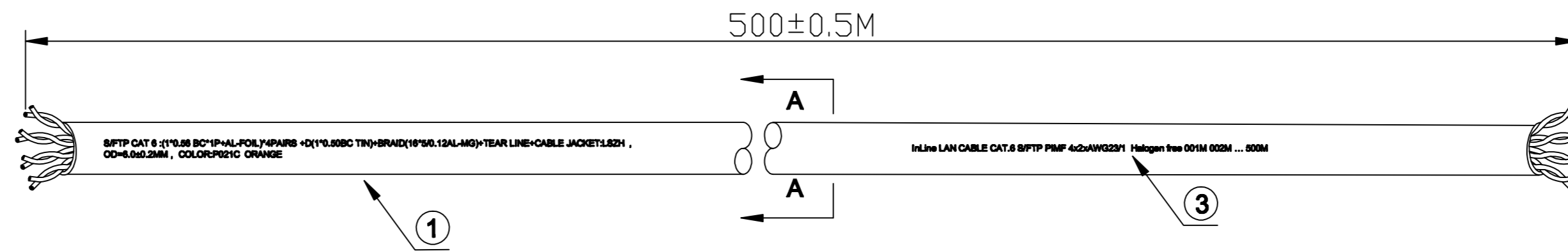

NOTE:
ELECTRICAL:100% OPEN SHORT & MISS WIRE TEST;
ALL MATERIAL BE ROHS & REACH COMPLIANT

⑤	TRENCHER	SIZE: $\phi 32.5 \times H30CM$	1	PCS
④	LABEL	The product labeling size:60*35MM, Carton label size:90*60MM	1	PCS
③	PRINTING	InLine LAN CABLE CAT.6 S/FTP PIMF 4x2xAWG23/1 Halogen free 001M 002M ... 500M		
②	PACKAGE	PE FILM, PAN SCROLLING		
①	CABLE	S/FTP CAT 6 :(1*0.56BC*1P+AL-FOIL)*4PAIRS+D(1*0.50BC TIN)+ BRAID(16*5/0.12AL-MG)+TEAR LINE+CABLE JACKET:LSZH , OD=6.0±0.2MM , COLOR:P021C ORANGE	500	M
No.	PART NAME	DESCRIPTION	QTY	REMARK

FRONT MARK

SIDE MARK

ITEM NO:
QTY: 1 PCS
PI NO:
N.W.:
G.W.:
EMAS:33*33*31CM

④ LABEL POSITION(2sides)

DRAW No.	NAME	S/FTP CAT 6 500M CABLE		
CUSTOMER	Inline	MAPE	TOLERANCE	
CUSTOMER No.	70505		X. ± 1.00	X.X ± 0.50
APPROVE BY	CHECK BY	DRAW BY	SCALE	MM
			PAGE	1/1